



iFlex Swing Gate

Swing Gates provide access and exit points for pedestrians. Available in two lengths, long and short.

The short gate has a hydraulic self-close feature to automatically return the gate to its closed position and maintain pedestrian safety. The long gate is supplied with additional post support for enhanced strength and stay-open access option for both pedestrians and vehicles.

Each gate has a double swing action, but are also supplied with gate stops to limit movement to one direction, forcing pedestrians to hesitate and pull the gate towards them. If desired, can be installed in pairs to increase the size of the opening.

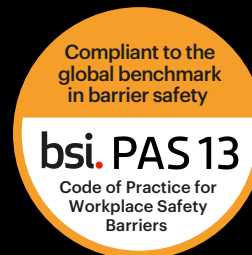

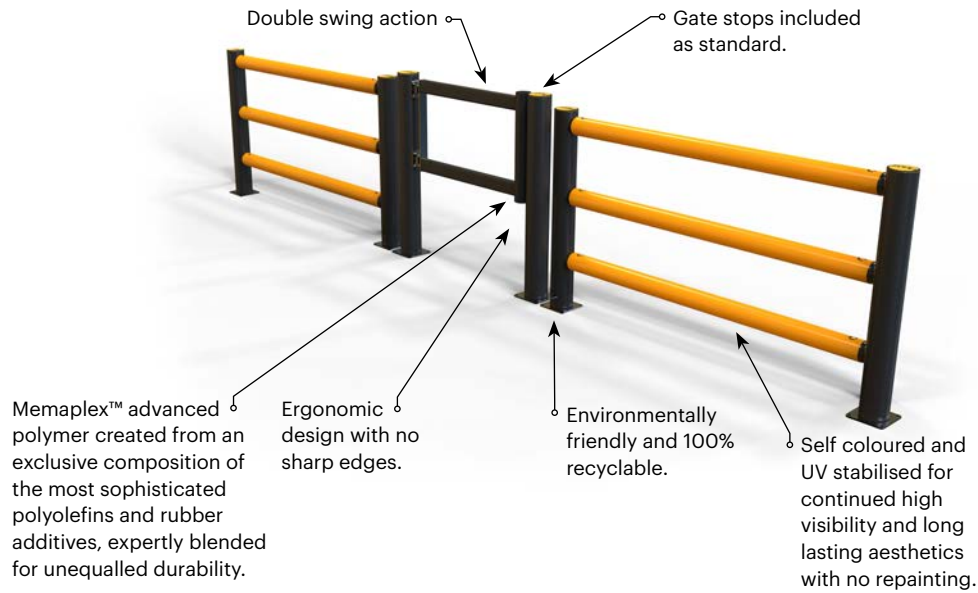

Swing Gate (Short)
Hydraulic self-close feature automatically returns the gate to its closed position after use to maintain safety.



Swing Gate (Long)
Extended gate length with additional post support for enhanced strength and stay-open access option.



Ultra-low maintenance material is chemical and water resistant, non-corrosive, non-scratch and self colored so no repainting, rusting, flaking or corrosion.



Twin-gate option allows the gate to be installed in pairs to provide a maximum opening of 2400mm for the Short Swing Gate and 4000mm for the Long Swing Gate.

Technical Information

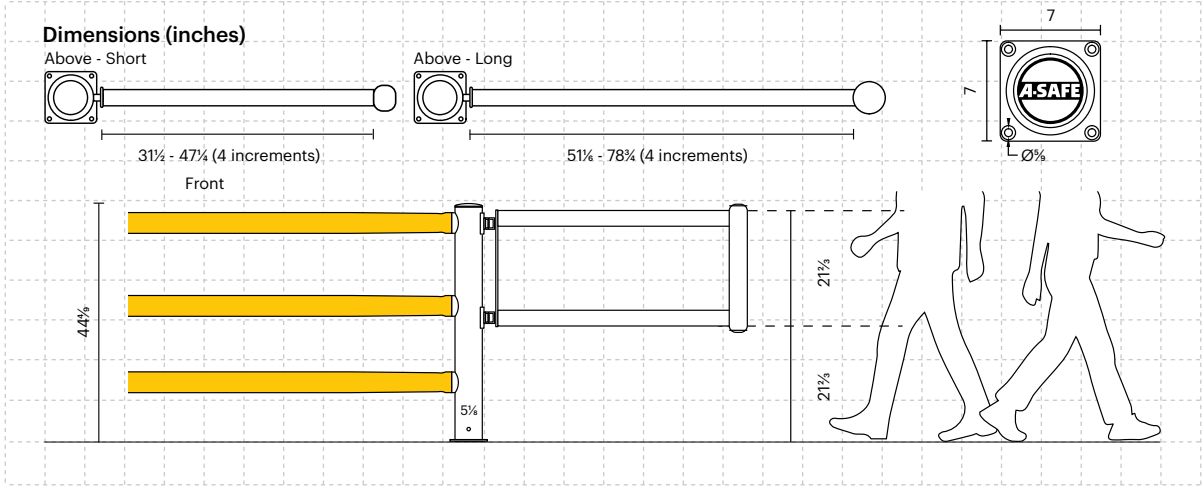

Post Options



Rail Option

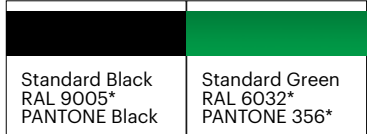

*Please note that the RAL and PANTONE colors listed are the closest match to standard A-SAFE colors, but may not be exact matches of the actual product color and should be used for guidance only.

