



Retractable Barrier Tape Racking Kit

The rack-mounted retractable barrier kit reduces the risk of accidents and pedestrian injuries by temporarily preventing vehicle access to racking aisles during manual activities such as maintenance and rack inspection. Easy to deploy and highly visible, the yellow and black chevron puller tapes serve as both a visual warning and a physical barrier.

The kit is fully portable and comes with a robust carry case, while multiple mounting options ensure self-retracting reel units and receivers can be quickly deployed on a wide range of racking systems.





2 x lockable self-retracting
354 1/2 inch tape reel



4 x receiver units
Attachment unit can be fitted using magnetic or cord-mounted fitments.



Reverse of unit showing the magnetic attachments



Products supplied in a robust carry case

Technical Information

Dimensions (inches)

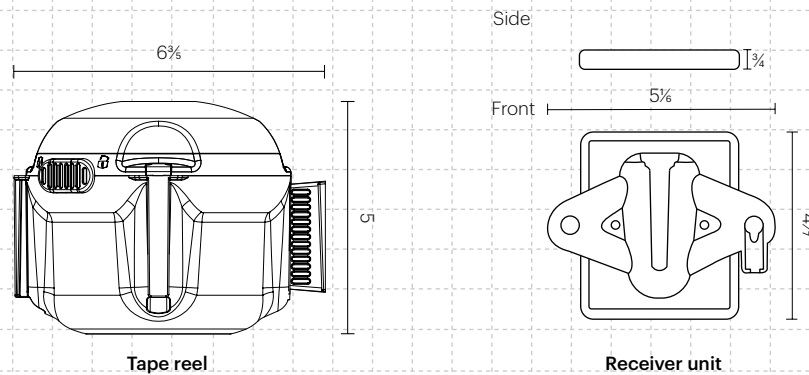

Tape reel attached via magnetic fitting

