



# iFlex Single RackEnd Guardrail

Designed to protect the end of racking aisles where turning vehicles and equipment can impact vulnerable racking structures.

This RackEnd guardrail provides heavy duty protection to shield racking systems from high impact accidents and prevent damage.

The circular end posts provide enhanced protection at the guardrail ends which are most susceptible to impact. Innovative spinning collars further deflect and dissipate impact forces.



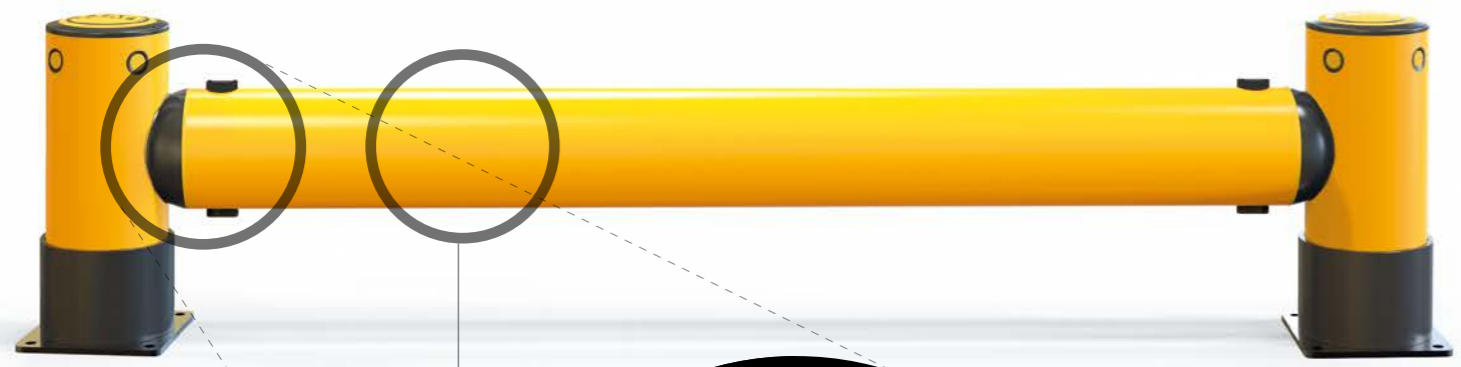

## MEMAPLEX™

**Ultimate strength polymer**  
 created from an exclusive composition of the most sophisticated polyolefins and rubber additives, expertly blended for unequalled strength and flexibility.

**Advanced Engineering Molecular**  
 reorientation during manufacturing creates a unique built-in memory that enables the guardrail to fully recover following impacts.

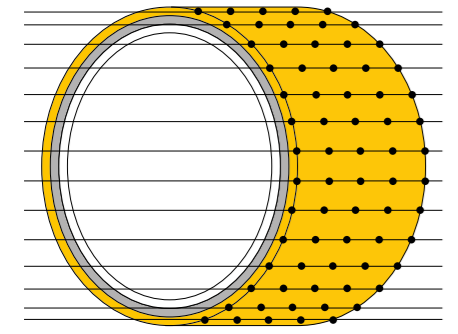

**Revolutionary 3-Layered Material**

- Inner strengthening core
- Central impact absorption zone
- Outer UV stabilised colour layer



## Energy Absorption System

A patented 3-phase system that activates sequentially for unparalleled energy absorption.

- 1 Memaplex™ rail flexes to absorb impact, initiating the rail pin to slide forward and transfer load energy to the compression pocket.
- 2 Compression of the pocket continues to disperse energy as the coupling rotates around the post pin to activate further absorption.
- 3 At peak energy, the coupling twists further, engaging the post pin and instigating torsion of the post to dispel remaining forces.

- A** Post Pin
- B** Coupling
- C** Rail Pin
- D** Compression Pocket
- E** Rail

## Suitability

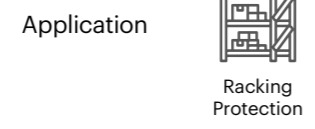

Unrivalled recovery through a unique built-in memory that allows the guardrail to flex, cushion and reform repeatedly upon impact, saving vast amounts in guardrail and vehicle repairs.

Huge return on investment from incident prevention and downtime avoidance as guardrails, vehicles, floors and equipment do not need replacing or repair.



## Features and benefits



Rotating wear collars deflect force from repeat glancing blows preventing expensive on-going maintenance costs.



Zinc nickel, electroplated coating on base plates as standard, provides advanced protection against corrosion damage.

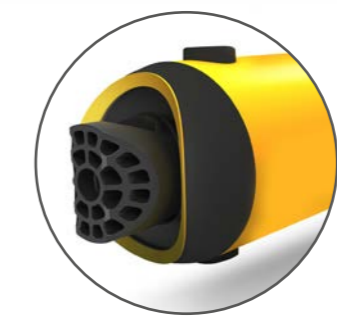

Exclusive modularity allows rails and posts to be replaced in-situ without removing adjacent guardrail sections.



Hygiene seals remove ingress points.



Ultra-low maintenance material is chemical and water resistant, non-corrosive, non-scratch and self coloured so no repainting, rusting, flaking or corrosion.



Self coloured and UV stabilised for continued visibility and long lasting aesthetics with no repainting.



No floor damage 80% of impact force is absorbed, transferring just 20% to the floor.

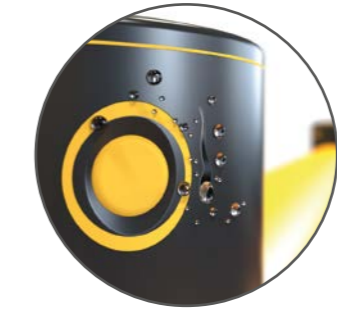

Food safe, wipe-clean, water resistant surface.



Ergonomic design with no sharp edges.



Environmentally friendly and 100% recyclable.



# Technical Information

How the energy from a vehicle impact is calculated

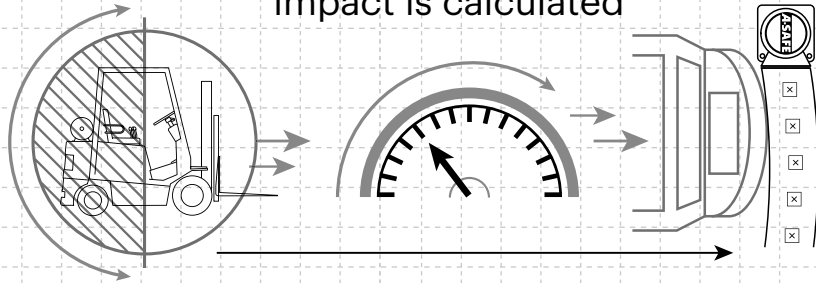

$$\frac{1}{2} \text{ Mass} \times \text{Speed}^2 = \text{Joules}$$

**Tested Impact Energy**

**30,200 Joules**

Equivalent vehicle and speed

**13.3 Ton** X **5 mph impact**

Mid Rail 45° Impact on 78¾ inch Post Centres

Dimensions (inches)

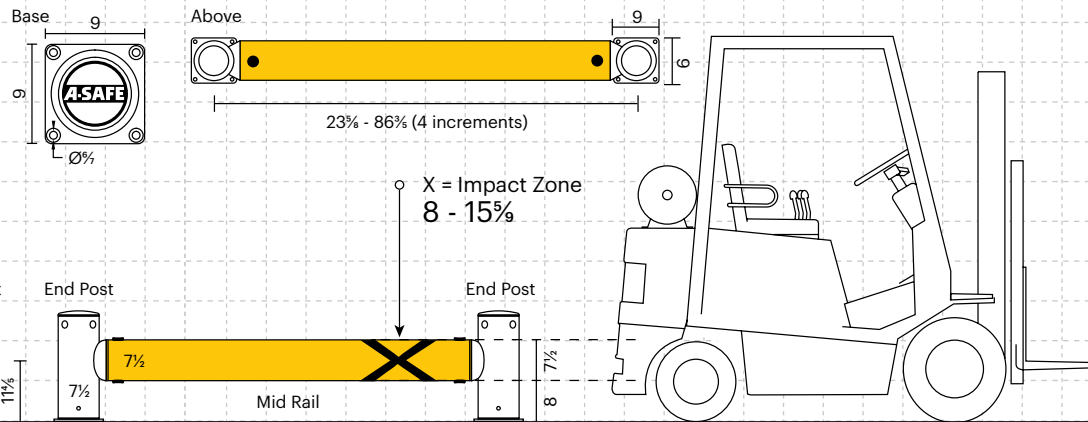

Impact Test	Impact Angle on 78¾ inch Post Centres			
	90°	67.5°	45°	22.5°
Mid Rail Max Energy (Joules)	15,100	17,691	30,200	103,109

End Post Max Energy (Joules) - 90°	<b>6,900</b>
------------------------------------	--------------

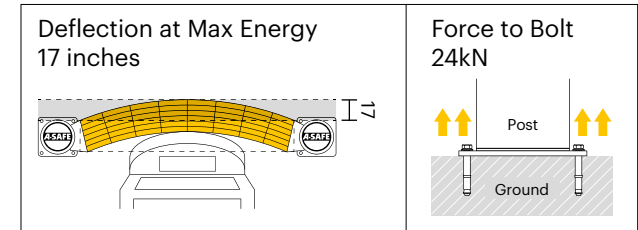

Material Properties	<b>MEMAPLEX™</b>
Temperature Range	-10°C to 50°C
Ignition Temperature	370°C to 390°C
Flash Point	350°C to 370°C
Toxicity	Not Hazardous
Chemical Resistance	Excellent - ISO/TR 10358
Weathering Stability (Grey Scale)	5/5*
Light Stability (Blue Wool Scale)	7/8**
Static Rating (Surface Resistivity)	1015 - 1016 Ω
Hygiene Seals	Yes

## Post Options



## Rail Options

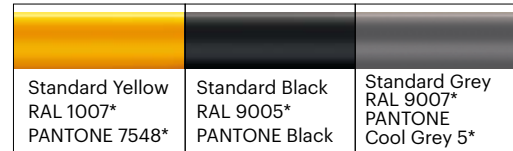

## Color Combinations

\*Please note that the RAL and PANTONE colors listed are the closest match to standard A-SAFE colors, but may not be exact matches of the actual product color and should be used for guidance only.

\* Weathering scale 1 is very poor and 5 is excellent  
\*\* Light stability scale 1 is very poor and 8 is excellent

