



# iFlex Heavy Duty Bollard

Designed to protect against damage caused by heavier weight vehicles or in higher speed environments.

The iFlex Heavy Duty Bollard is designed to protect structures and equipment from impact damage. Providing a robust physical presence to prevent access and guide vehicles.

Strong, durable and highly visible, A-SAFE Heavy Duty Bollards permanently reinforce a driver's attention to safe driving and provide enhanced protection against significant damage to property.





## MEMAPLEX™

### Ultimate strength polymer

created from an exclusive composition of the most sophisticated polyolefins and rubber additives, expertly blended for unequalled strength and flexibility.

### Advanced Engineering Molecular

reorientation during manufacturing creates a unique built-in memory that enables the bollard to fully recover following impacts.

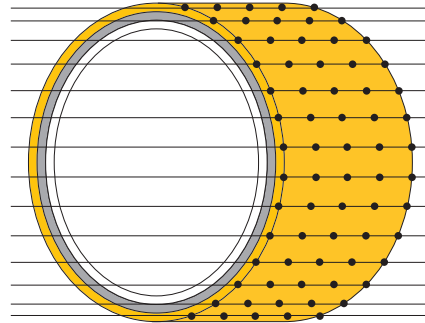

### Revolutionary 3-Layered Material

- Inner strengthening core
- Central impact absorption zone
- Outer UV stabilised colour layer



### In-line coupling for height flexibility

The iFlex in-line coupling introduces a new level of modularity to the vertical height of a range of A-SAFE products. The coupling enables customers to take the standard 1200mm bollard up to 2000mm.

- **Four pin positioning**  
to top and bottom sections gives increased rigidity and stability.
- **Seamless join**  
enables easy stacking of top and bottom bollard sections.
- **Moulded pins**  
lock securely into the internal layer with a quarter turn.

## Suitability

### Application



Suitable for pedestrians



Car Park protection



Column protection



Building and equipment protection



Airport mast and floodlight column protection



Industrial door protection

### Vehicle



Heavy Duty Counterbalance FLT



Engine Counterbalance Heavy Duty Forklift Truck



Electric Reach Truck



High Rack Stacker



Car



Small Van



Mini Van

Huge return on investment from incident prevention and downtime avoidance as bollards, vehicles, floors and equipment do not need replacing or repair.

## Features and benefits



Ideal for use on vehicle routes with sharp angle turns such as car parks.



Protect vulnerable access points where heavy duty vehicles are in operation.



The rotating wear collar adds an extra layer of protection along the full height of the bollard. The rotating action deflects force from repeat glancing blows. Preventing expensive on-going maintenance costs.



Higher level bollards give a strong visual alert for reversing HGV drivers, preventing costly damage to service yard infrastructure.

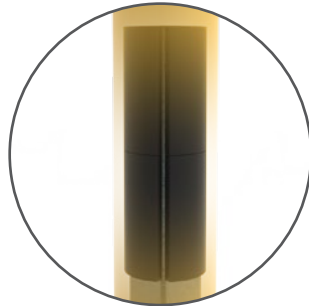

Energy absorbent foam creates permanent contact cushion between the internal and external structures.



# Technical Information

How the energy from a vehicle impact is calculated

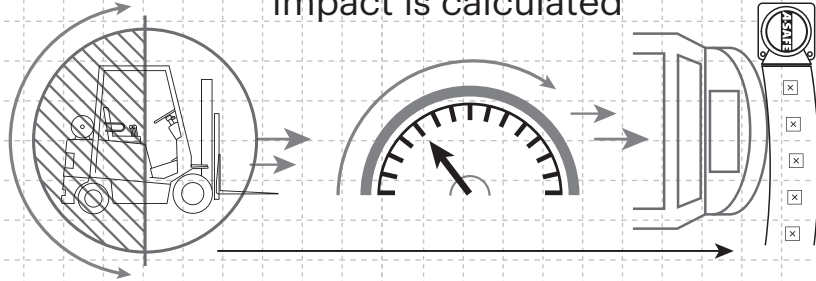

$$\frac{1}{2} \text{ Mass } \times \text{ Speed}^2 = \text{Joules}$$

Tested Impact Energy

**8,800 Joules**

Equivalent vehicle and speed

5.5 tonne **X** 4 mph impact  
90° Impact on Bollard

Dimensions (mm)

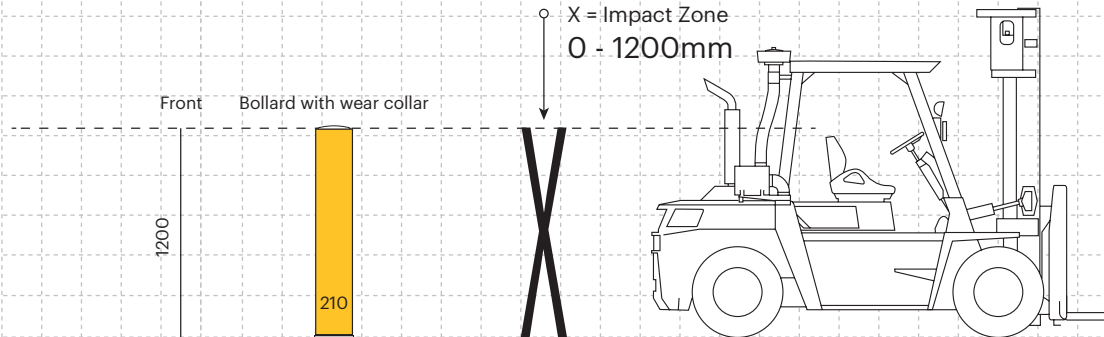
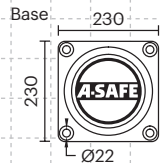

## Post Options



Standard Yellow  
RAL 1007\*  
PANTONE 7548\*



Standard Grey  
RAL 9007\*  
PANTONE  
Cool Grey 5\*

## Colour Combinations

\*Please note that the RAL and PANTONE colours listed are the closest match to standard A-SAFE colours, but may not be exact matches of the actual product colour and should be used for guidance only.

## Impact Test

Max Energy (Joules) at 90°

**8,800**

Deflection at Max Energy  
15° Lean

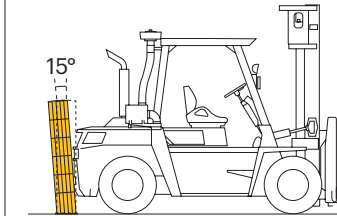

Force to Bolt  
35kN

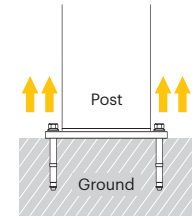

## Material Properties

**MEMAPLEX™**

Temperature Range	-10°C to 50°C
Ignition Temperature	370°C to 390°C
Flash Point	350°C to 370°C
Toxicity	Not Hazardous
Chemical Resistance	Excellent - ISO/TR 10358
Weathering Stability (Grey Scale)	5/5*
Light Stability (Blue Wool Scale)	7/8**
Static Rating (Surface Resistivity)	1015 - 1016 Ω

\* Weathering scale 1 is very poor and 5 is excellent

\*\* Light stability scale 1 is very poor and 8 is excellent

A-SAFE UK Ltd

Ainley House, Ainleys Industrial Estate, Elland, Halifax, HX5 9JP, United Kingdom

www.asafe.com

