



RackGuard Rack Leg Protector

Designed to protect vulnerable rack legs from front, side and scrape impacts by workplace vehicles.

RackGuard protectors absorb and deflect impacts, transferring energy around the rack leg rather than through it, preventing damage to uprights and maintaining the structural integrity of racking systems.

Frictional grip points ensure a secure fit to any sized rack leg.



Ultra-low maintenance material is chemical and water-resistant, non-corroding, non-scratch and self-coloured, so no repainting, rusting, flaking or corrosion.



Huge return on investment from incident prevention and downtime avoidance as guardrails, vehicles, floors and equipment do not need replacing or repair.



Rigorously tested to fully comply with EN 15512, EN 15635 and the Australian standard AS 4084



Independently certified by world-leading test experts TÜV Nord



A rubber compression hinge provides added strength under impact, improving performance and longevity.

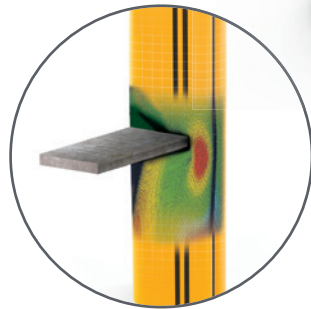

Molecular reorientation during manufacturing creates a unique built-in memory that enables the RackGuard to fully recover following impacts.



Dual branding option RackGuard can be personalised with your company logo to create a unified branding experience throughout your warehouse facility.



RackGuard works with a specially designed Installation Toolkit (sold separately) to ensure it can be installed and removed easily.

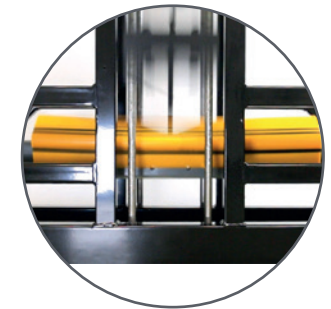

RackGuard has been rigorously tested to fully comply with the highest standards for storage equipment, including EN 15512, EN 15635 and the Australian standard AS 4084. Furthermore, testing has been independently verified by TÜV Nord – one of the world's leading independent test organisations – for total peace of mind.



Cold Storage option available. Purpose engineered for cold storage temperatures as low as -30°C. See separate data sheet for details.

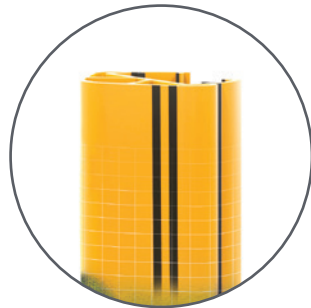

Memaplex™ ultimate strength polymer is an exclusive composition of the most sophisticated polyolefins and rubber additives that have been blended by experts to provide unparalleled strength and flexibility.



Ergonomically designed with a slim profile to limit intrusion into warehouse aisles.



Eco-friendly and 100% recyclable.



RackGuards can also be installed above ground level to protect racks from loading and unloading damage.



Technical Information

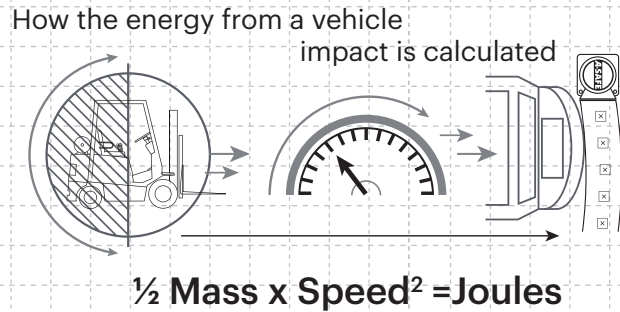

Tested Impact Energy

1,000 Joules

Equivalent vehicle and speed

3.3 ton x **1.8 mph** impact
90° Impact on RackGuard

RackGuard Profiles

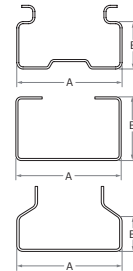

RackGuard Sizes

Description	A-Rack width (max)	B-Rack depth (max)
RackGuard (S) SL	4	1%
RackGuard (S) ML	4	2%
RackGuard (S) LL	4	3%
RackGuard (S) SLR	3%	1%
RackGuard (S) MLR	3%	2%
RackGuard (S) LLR	3%	3%
RackGuard (L) SL	5	3
RackGuard (L) SLR	4%	3

All RackGuards are available in 15% and 23% inch heights.

Impact Test

Max Energy (Joules) **1,000**

Deflection at Max Energy
 $\frac{4}{5}$ inch

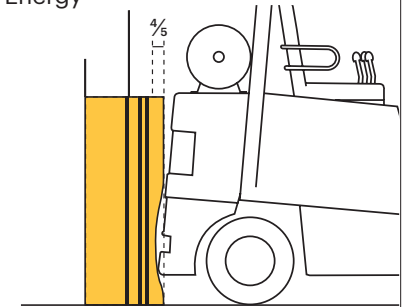

Dimensions (mm)

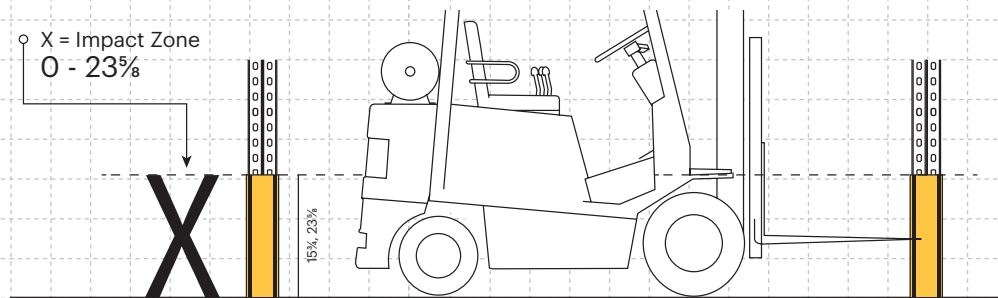

Material Properties

MEMAPLEX™

Temperature Range	14°F to 122°F
Ignition Temperature	698°F to 734°F
Flash Point	662°F to 698°F
Toxicity	Not Hazardous
Chemical Resistance	Excellent - ISO/TR 10358
Weathering Stability (Grey Scale)	5/5*
Light Stability (Blue Wool Scale)	7/8**
Static Rating (Surface Resistivity)	$10^{15} - 10^{16} \Omega/\text{sq}$

* Weathering scale 1 is very poor and 5 is excellent

** Light stability scale 1 is very poor and 8 is excellent

Compression hinges have various widths to fit a range of racking profiles.

RackGuard (S) SL, ML, LL

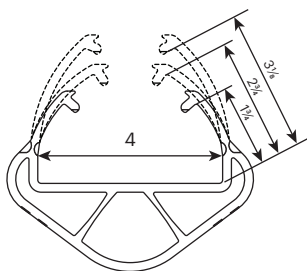

RackGuard (S) SLR, MLR, LLR

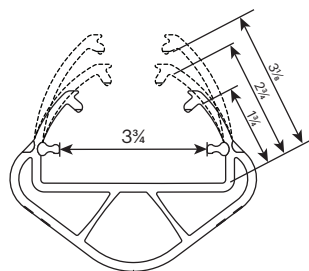

RackGuard (L) SL

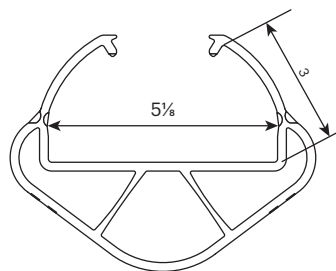

RackGuard (L) SLR

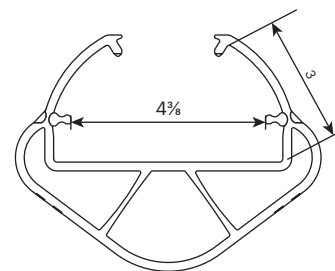

A-SAFE Inc

400 North Zarfoss Drive York, PA 17404

Tel: (443) 776 3472 Email: sales@asafe.us www.asafe.com

