



# iFlex Single Car Park Barrier

iFlex Single Car Park Barrier is designed to shield ramps, entrance points, perimeters, walls and walkways from vehicle damage.

A-SAFE car park barriers are certified to EN1991, BS6399 and BS6180/DETR standards. These flexible barriers significantly reduce repair and maintenance costs, as they are designed to absorb and dissipate vehicle impact forces before fully recovering. This preserves flooring substrates, avoids barrier repairs and minimises damage to the vehicles.



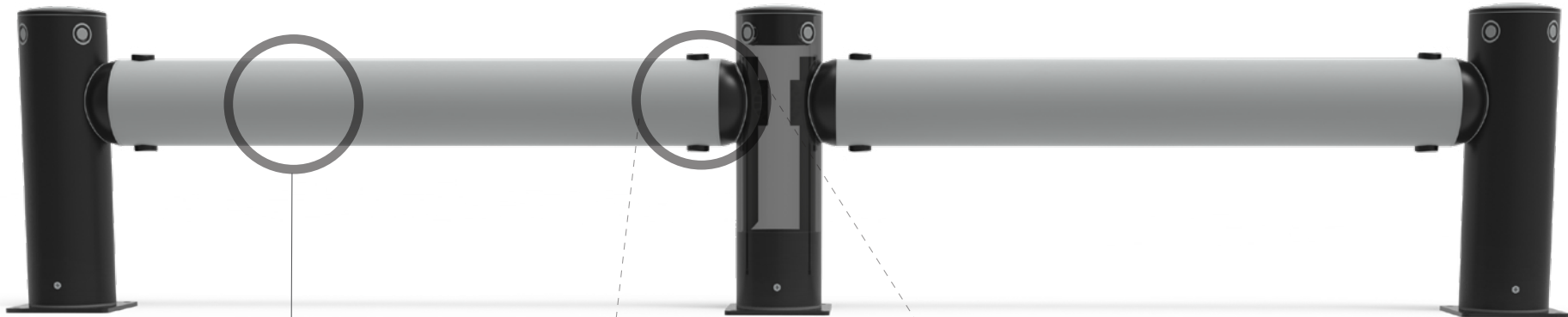

# MEMAPLEX™

## Ultimate strength polymer

created from an exclusive composition of the most sophisticated polyolefins and rubber additives, expertly blended for unequalled strength and flexibility.

## Advanced Engineering Molecular

reorientation during manufacturing creates a unique built-in memory that enables the barrier to fully recover following impacts.

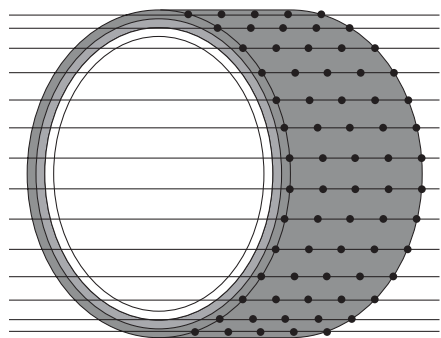

### Revolutionary 3-Layered Material

- Inner strengthening core
- Central impact absorption zone
- Outer UV stabilised colour layer

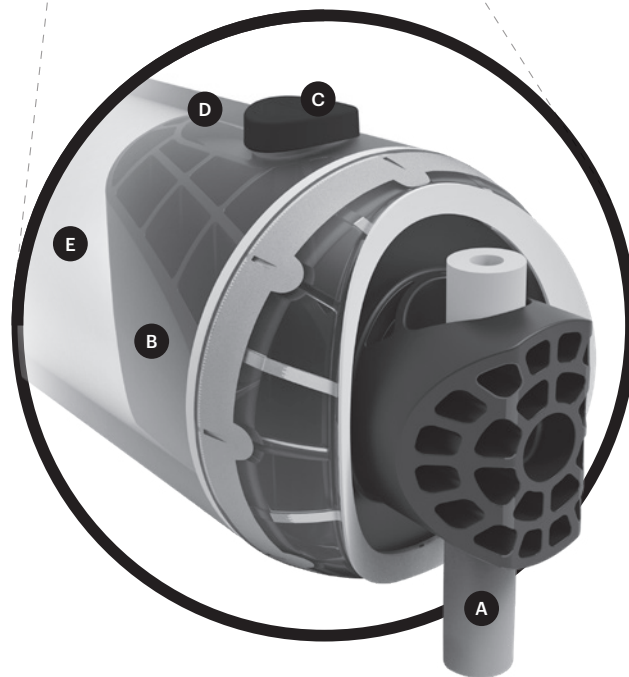

## Energy Absorption System

A patented 3-phase system that activates sequentially for unparalleled energy absorption.

- 1 Memaplex™ rail flexes to absorb impact, initiating the rail pin to slide forward and transfer load energy to the compression pocket.
- 2 Compression of the pocket continues to disperse energy as the coupling rotates around the post pin to activate further absorption.
- 3 At peak energy, the coupling twists further, engaging the post pin and instigating torsion of the post to dispel remaining forces.

- |                   |                             |
|-------------------|-----------------------------|
| <b>A</b> Post Pin | <b>D</b> Compression Pocket |
| <b>B</b> Coupling | <b>E</b> Rail               |
| <b>C</b> Rail Pin |                             |

## Suitability

Vehicle



Car



Mini Van



Small Van

Application



Protects parking structures



Unrivalled recovery through a unique built-in memory that allows the barrier to flex, cushion and reform repeatedly upon impact, saving vast amounts in barrier and vehicle repairs.

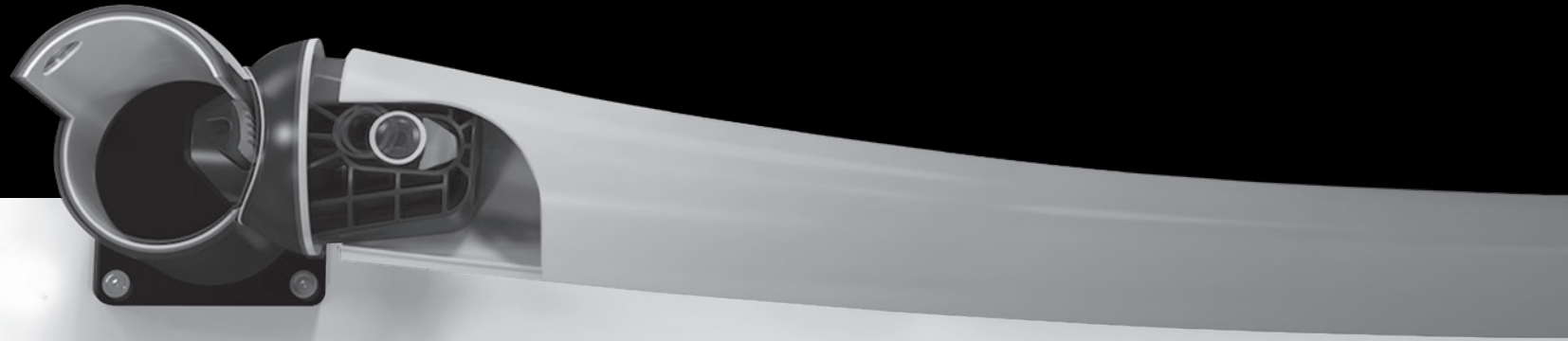

Huge return on investment from incident prevention and downtime avoidance as barriers, vehicles, floors and equipment do not need replacing or repair.

## Features and benefits



Multi-directional system ensures a streamlined fit into any operation and the removal of hard angles.



Ultra-low maintenance material is chemical and water resistant, non-corrosive, non-scratch and self coloured so no repainting, rusting, flaking or corrosion.



Exclusive modularity allows rails and posts to be replaced in-situ without removing adjacent barrier sections.



Seals reduce the risk of water ingress.



Zinc nickel, electrophoretic coating on base plates as standard, provides advanced protection against corrosion damage.



Self coloured and UV stabilised for continued visibility and long lasting aesthetics with no repainting.



No floor damage 80% of impact force is absorbed, transferring just 20% to the floor.

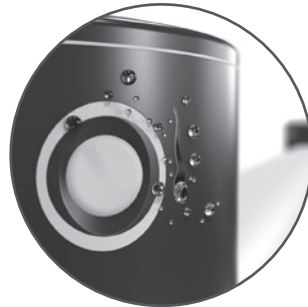

Wipe-clean, water resistant surface.



Ergonomic design with no sharp edges.



Environmentally friendly and 100% recyclable.



# Technical Information

How the energy from a vehicle impact is calculated

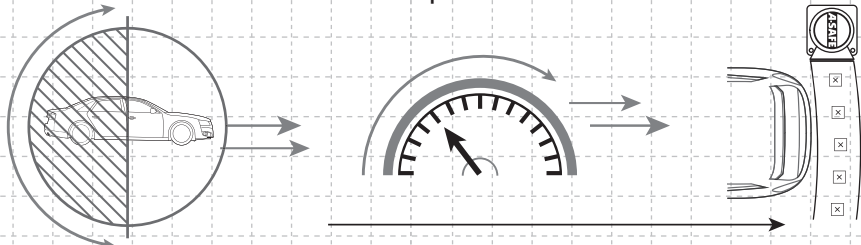

$$\frac{1}{2} \text{ Mass} \times \text{Speed}^2 = \text{Joules}$$

## Tested Impact Energy

**30,200 Joules**

Equivalent vehicle and speed



3 tonne

**X 10 mph impact**

Mid Rail 45° Impact on 2000mm Post Centres

### Dimensions (mm)

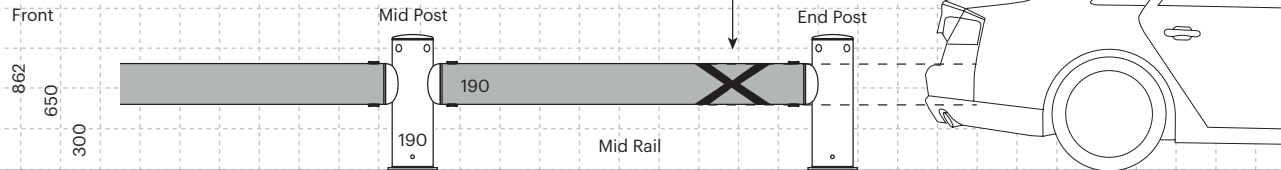
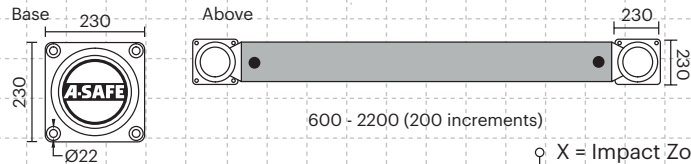

Impact Test	Impact Angle on 2000mm Post Centres			
	90°	67.5°	45°	22.5°
Mid Rail Max Energy (Joules)	15,100	17,691	30,200	103,109

End Post Max Energy (Joules) - 90°	6,900
End Post Max Energy (Joules) - 90°	6,900

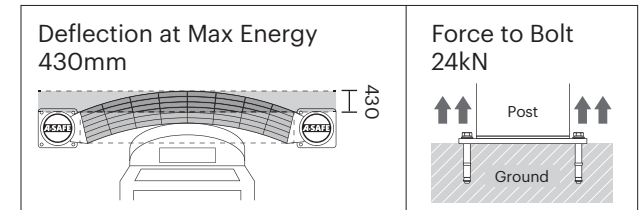

Material Properties	MEMAPLEX™
Temperature Range	-10°C to 50°C
Ignition Temperature	370°C to 390°C
Flash Point	350°C to 370°C
Toxicity	Not Hazardous
Chemical Resistance	Excellent - ISO/TR 10358
Weathering Stability (Grey Scale)	5/5*
Light Stability (Blue Wool Scale)	7/8**
Static Rating (Surface Resistivity)	1015 - 1016 Ω

### Post Options



### Rail Options

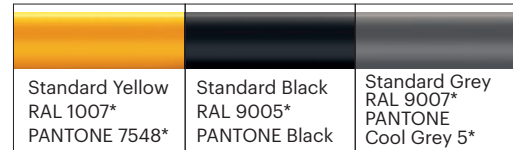

### Colour Combinations

\*Please note that the RAL and PANTONE colours listed are the closest match to standard A-SAFE colours, but may not be exact matches of the actual product colour and should be used for guidance only.

\* Weathering scale 1 is very poor and 5 is excellent  
 \*\* Light stability scale 1 is very poor and 8 is excellent

